

**BOYD LITE**



**ROCKLABS  
BOYD LITE**



## Big inputs and accurate outputs for seriously reliable results.

The Rocklabs Boyd Lite utilizes our double acting fine jaw crushing design, with an input size of up to 70mm.

Featuring top and bottom moving jaws, the Crusher delivers the maximum amount of crushing, reducing samples by 35 times the original size.

### Benefits:

- Designed for easy operation
- Simplified maintenance
- Stringent safety mechanisms
- Top and bottom moving jaws
- Improved ergonomics

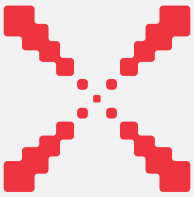

### Electrical

Voltage VAC	Phases	Frequency Hz	Current A	Power kW
380-415	3 Phase 4 wire	50	19	5.5

### Dust Extraction

	Minimum	Maximum
Flow Rate	2.15m <sup>3</sup> /min (75 foot <sup>3</sup> /min)	2.45m <sup>3</sup> /min (85 foot <sup>3</sup> /min)



Input Size	<b>70mm</b>
Output	<b>2mm</b>
Jaw Width	<b>300mm</b>
Capacity	<b>5kg</b>



	Product
Height	<b>1500mm</b>
Width	<b>675mm</b>
Depth	<b>790mm</b>
Weight	<b>550kg</b>

# ROCKLABS BOYD LITE

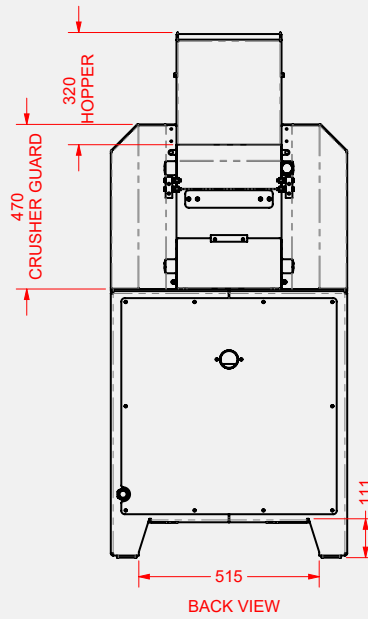
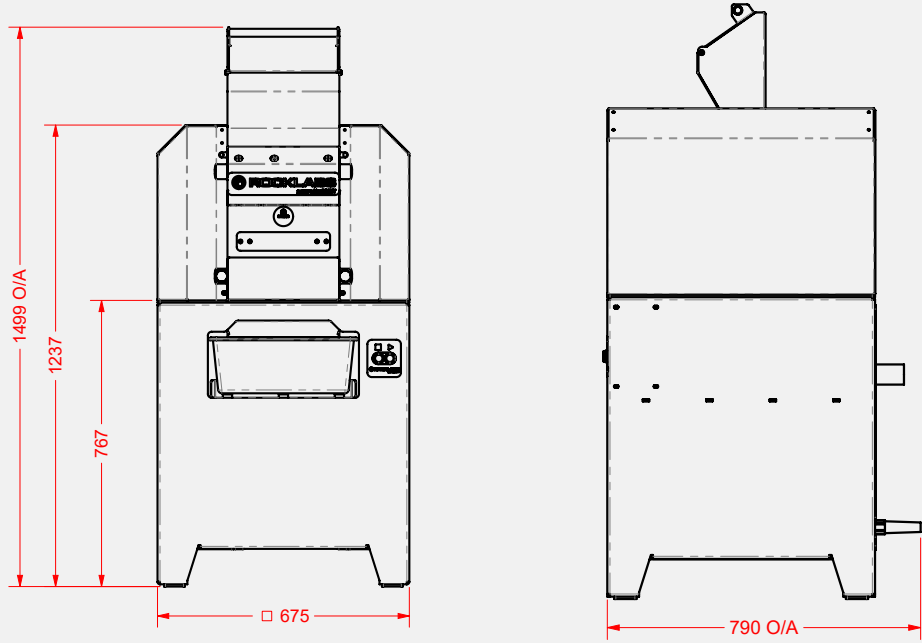
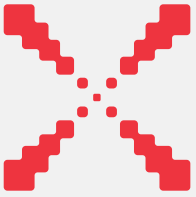

**Powered by Scott for worldwide support.**

All maintenance and servicing is backed by international technology and automation company, Scott, for worldwide support.